

ADHESIVE WORKHOLDING
the universal part gripping solution

Product Catalog

2024-2025

Welcome to the Blue Photon Workholding System

Blue Photon's revolutionary grip technology is designed to hold parts securely while eliminating problems with traditional workholding like distortion and machine access.

It's time to throw away your clamps and discover the world of adhesive workholding@!!



blue photon®

Technology & Workholding Systems LLC



GRINDING

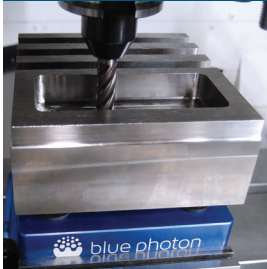

MILLING



TURNING



ECM & EDM

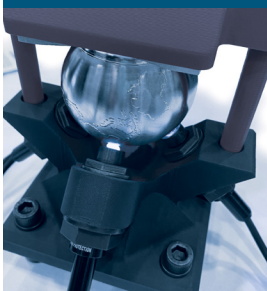

ADDITIVE

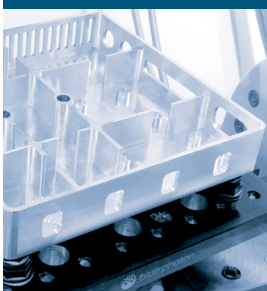

5-AXIS

THE BLUE PHOTON DIFFERENCE

Blue Photon's unique, versatile system blows traditional workholding away!

With this revolutionary solution, you will enjoy fewer operations, less scrap, improved machine access, improved accuracy and much more!!!

If your workholding goals include cost savings, Blue Photon is the solution for you!

APPLICATION VERSATILITY

From machining optical glass to medical and jet propulsion components, Blue Photon is unlike any workholding system in the world.

Are you Milling? Grinding? Additive Manufacturing?

Regardless of your application type, Blue Photon's adhesive workholding® provides the holding power AND part accessibility that you require to machine complex-shaped or near-net shaped parts.

COMPATIBILITY

Don't throw away your current workholding system!

Blue Photon fixture systems are compatible with many industry standard workholding solutions including:

- 5th Axis
- Erowa
- Jergens
- Lang
- Mate
- Schunk
- Others!

SWITCH TO BLUE PHOTON FOR THE COMPETITIVE ADVANTAGE YOU'VE BEEN WAITING FOR!



TABLE OF CONTENTS

INTRODUCTION

USING BLUE PHOTON Step-by-Step.....	6
--	---

BASE WORKHOLDING COMPONENTS.... 7

Grippers (Head-In & Head-Out)	9
Workholding Adhesive®	10
Inserts (External & Internal)	11

UV CURING

LED Controllers	13
Right Angle Adapters	13
Gripper Adapters	13
UV LED Head Assemblies	14
UV LED Heads Without Adapters	14

ADHESIVE CLEANING

Heavy Duty Steam Cleaners	15
Scrapers	16
Pressurized Neat™ Steam Cleaning	16
Heated Soak Tank & Accessories	16
CNC Spindle Mounted Cleaning Tool	15

Workholding Kits	18
------------------------	----

ACCESSORIES 19

GRIPPER ACCESSORIES

Ratchets.....	22
Thin Wall Deep Well Sockets.....	22
Shims	22

ADHESIVE DISPENSING

Adhesive Dispensers	23
Adhesive Dispenser Accessories	24
3D Printed Barrel Loader	24

SAFETY & MORE!

UV Safety Glasses	24
Hand Held Radiometer	24
Hard Case	24

ADHESIVE DISPENSING ACCESSORIES

Syringe/Cartridge Barrels & Accessories	26
Tip Caps	26
End Caps	26
Dispenser Accessories	26

WORKHOLDING FIXTURE SYSTEMS..... 27

Grip Pallets	29
Part Spacers	30
Clamp Studs	30
Universal Fixture Kit	31

PART STABILIZATION

Puck Bases	33
5-Axis Adjustable Stabilizer Bases	33
5-Axis Fine Adjustable Stabilizer Extension	33
Stabilizer Mounting Screws	34
5-Axis Stabilizer Ball & Collars	34
5-Axis Stabilizer Magnetic Bases	34

WARRANTY INFORMATION 35

Warranty Information	36
----------------------------	----



INTRODUCTION USING BLUE PHOTON

Improved Workholding is a Breeze With Blue Photon!

SUPERIOR HOLDING IN A FEW SIMPLE STEPS

Apply these simple steps to use the Blue Photon workholding system effectively:



STEP 1
Clean dirt and oil from the grippers and workpiece.



STEP 2
Apply enough adhesive to the grippers to fully fill the gap between the part and gripper.

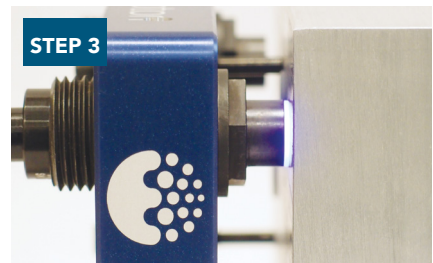

STEP 3
Apply ultraviolet (UV) light for 60 seconds to cure adhesive.

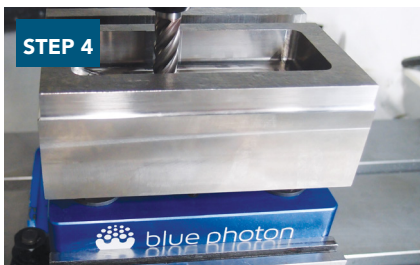

STEP 4
Machine your workpiece.

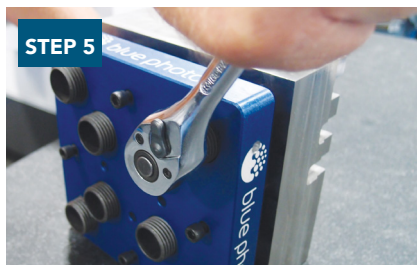

STEP 5
Separate fixture from workpiece with a 1/4 turn twist or hot water soak.



STEP 6
Remove and peel away residual adhesive with steam or hot water spray.

GETTING STARTED

Before you begin, carefully review the Blue Photon user guide. In particular, pay attention to warnings and cautions in the safety and design sections located in the front of the manual.

Visit our website for the most up-to-date product and safety guidelines.

Blue Photon System Base Workholding Components

The Blue Photon Workholding System is a patented, photo-activated adhesive fixturing and workholding solution whose basis consists of patented, load bearing, & light transmitting grippers and specially designed BlueGrip™ workholding adhesive®.



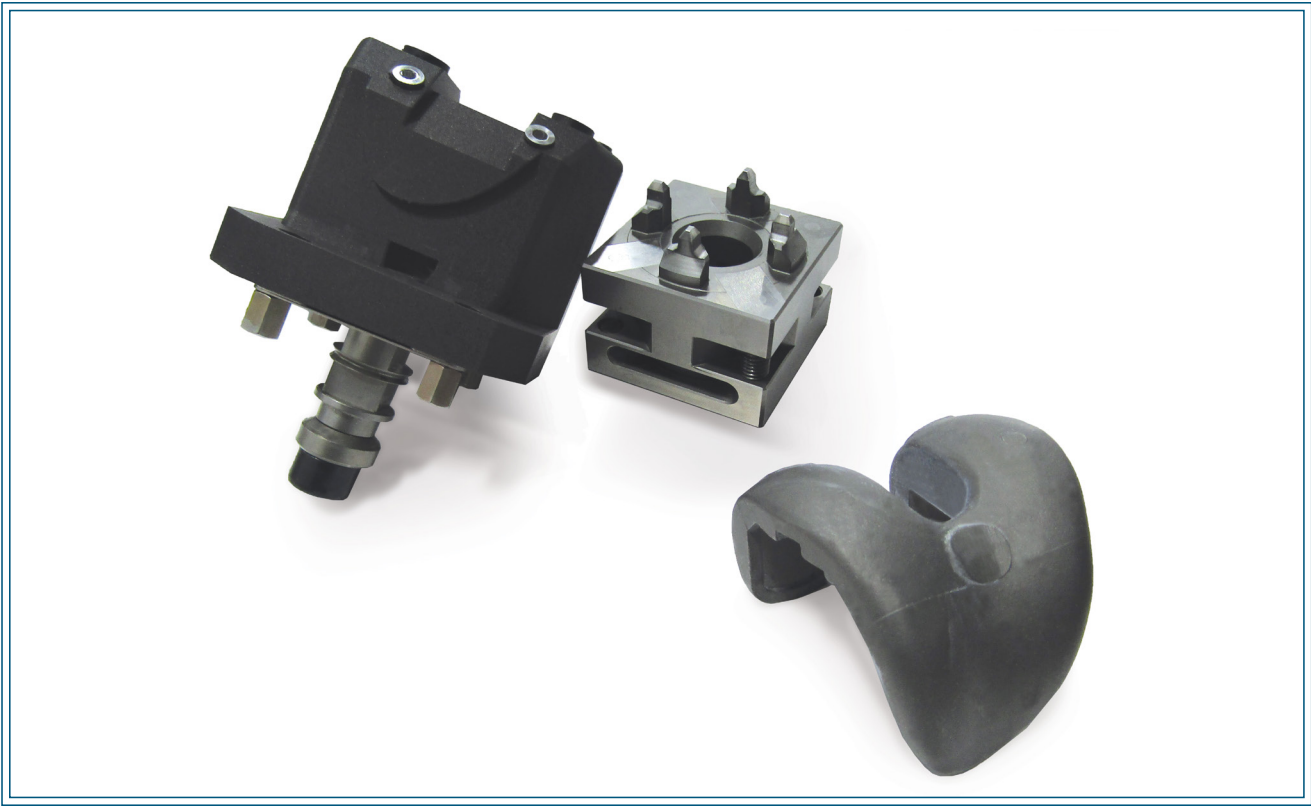

Project Spotlight - Knee Implant

Challenge: Part movement during machining due to the complex shape of the part and the associated restrictive geometrical and dimensional requirements.

A medical device manufacturer was machining a knee implant component out of cobalt-chromium and was struggling with part movement.

The Blue Photon grip technology solved the customer’s workholding struggles while eliminating scrap and re-work caused by poor clamping. Their workholding issues were solved AND the surface quality of the part was improved.



Get a Grip With Blue Photon Grippers!

Blue Photon's unique workholding grippers are patented, load bearing and light transmitting fixture components. They are inserted into a fixture and secured to your workpiece with BlueGrip™ workholding adhesive® which is cured with UV light transmitted through the gripper core.

Grippers easily separate from your workpiece with 1/4 turn of the gripper or a hot water soak.

Choose From Two Gripper Styles

HEAD-IN GRIPPERS

- Fixture inserted from the back side.
- Gripper can be retracted during workpiece loading.
- Use with internal and external Inserts.

HEAD-OUT GRIPPERS

- Holds delicate and complex parts.
- Fixture inserted from the top side.
- Gripper cannot be retracted during workpiece loading.

Part Number	Size	DIA (mm)	Style	Type	Average Tensile Holding Power with BlueGrip™ S2*
14130	Small	7.75	Head-In	Standard	100 lbs
14131			Head-In	Corrosion Resistant**	
14230			Head-Out	Standard	
14231			Head-Out	Corrosion Resistant**	
15130	Medium	11.75	Head-In	Standard	400 lbs
15131			Head-In	Corrosion Resistant**	
15230		12.45	Head-Out	Standard	
15231			Head-Out	Corrosion Resistant**	
16160	Large	14.75	Head-In	Standard	605 lbs
16161			Head-In	Corrosion Resistant**	
16260			Head-Out	Standard	
16261			Head-Out	Corrosion Resistant**	

* Testing done under controlled conditions

** Use corrosion resistant models where deionized water or acid is used.

** CNC spindle mounted cleaning tool cannot be used with corrosion resistant grippers.



Contact us today to get started - 855-777-2040 • www.BluePhotonGrip.com • Sales@BluePhotonGrip.com

BlueGrip™ Adhesive - Hold on Tight!

With BlueGrip™ workholding adhesive®, nothing is too hard to hold!

BlueGrip workholding adhesive® is designed specifically and exclusively for the Blue Photon workholding system.

The gel-like adhesive fills the gap between the surface of the gripper and the workpiece surface for outstanding holding power.

BLUEGRIP™ WORKHOLDING ADHESIVE®

- Works on ferrous and non-ferrous metals, ceramics, composite materials and some plastics.
- Cures in 60 to 90 seconds.
- Impervious to cutting fluids and oils.
- Cured adhesive is removable with a CNC machine mounted cleaning tool, hot water, steam, hot water spray or dry ice blasting.
- Fills gaps of .020" to .120" between the gripper and the workpiece.
- Available with fluorescent dye for easy identification of residual adhesive.

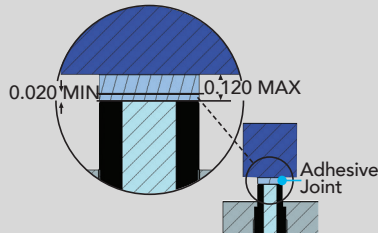

Part Number	Size	Style	Description
43200	30cc syringe	BlueGrip™ S2 Regular	Use for manual and pneumatic dispensing
43210		BlueGrip™ S2 Fluorescent	
46200	1 liter cartridge	BlueGrip™ S2 Regular	Use for automated dispensing
46210		BlueGrip™ S2 Fluorescent	
48300	40lb/5 Gallon Pail	BlueGrip™ S3 Regular	Use for automated dispensing

Workholding adhesive® dispensing tools are found on page 23.



Go to www.BluePhotonGrip.com for additional product info and to download tech specs.



INSERTS



Protect Fixture Threads With Inserts.

Blue Photon inserts protect your aluminum fixture threads from heavy usage. Select external inserts when additional height is required.

Adjustable Insert Assemblies

- Includes the gripper insert and nut to increase standoff from the fixture.
- Allows for height adjustments.
- Use to increase standoff from the fixture and/or to protect aluminum fixtures from thread galling.
- Inserts into fixture from the top.
- Manufactured from hardened steel with a black oxide finish.

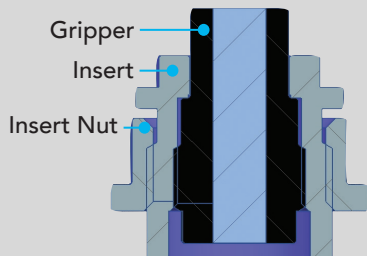

Internal Inserts

- Thread locked into the fixture.
- Insert into fixture from the backside.
- Install with thread locker.
- Workpiece separates from gripper with 1/4 turn of gripper or hot water soak.
- Manufactured from hardened steel with a black oxide finish.

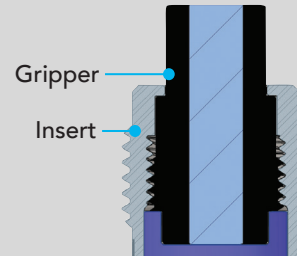

Pallet Fixed Inserts

- Available in large sizes fitting small, medium or large head-in grippers.
- Inserts increase standoff from the fixture.
- Made from hardened steel with a black oxide finish.
- Inserts into fixture from the top.





External and Internal Inserts

Part Number	Size	Gripper Included?	Compatible Gripper(s)
Adjustable Insert Assemblies			
24200	Small	No	14130/14131
25200	Medium	No	15130/15131
26200	Large	No	16160/16161
Pallet Fixed Inserts			
24211	Small	No	14130
24219	Small	Yes	Gripper Included
25211	Medium	No	15130
25219	Medium	Yes	Gripper Included
26211	Large	No	16160
26219	Large	Yes	Gripper Included
Internal Inserts			
24100	Small	No	14130/14131
25100	Medium	No	15130/15131
26100	Large	No	16160/16161

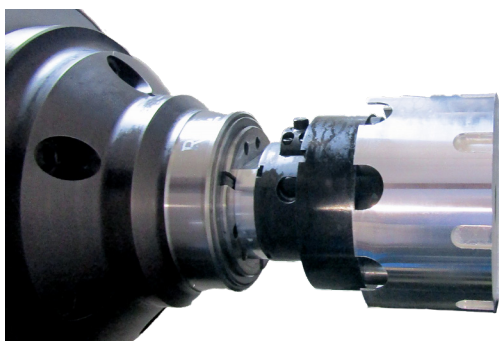

UV CURING



Lock Down Your Workpiece - UV Curing Equipment

BLUEGRIP™ S2 Workholding Adhesive® cures quickly when exposed to UV light. The curing process is 60-90 seconds with Blue Photon's patented system of UV LED controllers and UV LED heads. Controllers are capable of operating multiple UV LED heads and are available with up to 8 channel configurations.



UV LED CONTROLLERS

Part Number	Size	Light Head Capability	Display Size	Description
65440	BlueCure Mini 4*	1-4	2.4"	4 channel UV LED Controller
65449	BlueCure 8*	1-8	3.75"	<ul style="list-style-type: none"> 8 channel UV LED Controller Touch screen display Password protected to save controller settings and avoid unwanted changes.

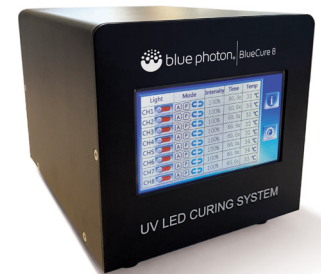

- * Screen displays main control information, input configurations, system maintenance and LED information.
- * Screen displays alarm icon in the event of an error or fault.
- * Foot pedal is included for external operation.

RIGHT ANGLE ADAPTERS*

Attaches to the UV LED head when clearance issues arise in tight spaces.

Part Number	Size	Type	Compatible Gripper Size
64850	Medium	Standard	Medium
64860	Medium	Extended	Medium
64950	Large	Standard	Large
64960	Large	Extended	Large



- * Right angle adapters cure the adhesive in 90 seconds.

GRIPPER ADAPTERS

Gripper adapter for UV LED heads.

Part Number	Size
51705	Small
52705	Medium
57705	Large



UV LED HEAD ASSEMBLIES

Cures BlueGrip™ workholding adhesive® through the grippers.

Part Number	Adapter Size	Head Length	Cable Length	Type
52802	Small	56mm	2M	Standard Length
52855	Small	56mm	5M	Long Reach
52850	Small	56mm	10M	Extra Long Reach
53802	Small	85mm	2M	Standard Length
53855	Small	85mm	5M	Long Reach
53850	Small	85mm	10M	Extra Long Reach
52803	Medium	56mm	2M	Standard Length
52865	Medium	56mm	5M	Long Reach
52860	Medium	56mm	10M	Extra Long Reach
53803	Medium	85mm	2M	Standard Length
53865	Medium	85mm	5M	Long Reach
53860	Medium	85mm	10M	Extra Long Reach
52804	Large	56mm	2M	Standard Length
52875	Large	56mm	5M	Long Reach
52870	Large	56mm	10M	Extra Long Reach
53804	Large	85mm	2M	Standard Length
53875	Large	85mm	5M	Long Reach
53870	Large	85mm	10M	Extra Long Reach



UV LED HEADS WITHOUT ADAPTERS

Cures BlueGrip workholding adhesive® through the grippers.

Part Number	Head Length	Cable Length	Type
52812	56mm	2M	Standard Length
53812	85mm	2M	Standard Length
52815	56mm	5M	Long Reach
53815	85mm	5M	Long Reach
52810	56mm	10M	Extra Long Reach
53810	85mm	10M	Extra Long Reach



UV CURING

ADHESIVE CLEANING







Easy Clean-Up!

Blue Photon steamers and equipment make adhesive removal a breeze!

HEAVY DUTY STEAM CLEANERS

Easily clean cured adhesive from grippers and workpieces with 60 PSI of continuous steam pressure and temperatures up to 221°F at the cleaning tip.

- Low water light indicator
- 12-gauge heavy duty wiring
- Stainless steel tank and outer casing

Part Number	Hours of Working Time	Heating Element	Water Capacity	Heat Up Time	Description
84870	Approx 6	110V/120V 1200W	1.25 gallon 4.5 liter	15-20 min	<ul style="list-style-type: none"> • 61 PSI, 4.1 bar operating pressure • Pressure/safety switch • 30A heavy-duty contactor • Carrying handle 
84880	Minimum 8	110V/120V 1200W	2.37 gallon 9 liter	30-40 min	<ul style="list-style-type: none"> • Visual water level indicator • Uses regular tap water • Ranco pressure control • Carrying handle • 2 incoloy heating elements (1 spare) 
84881	Minimum 8	220V	2.37 gallon 9 liter	30-40 min	<ul style="list-style-type: none"> • Visual water level indicator • Uses regular tap water • Ranco pressure control • Carrying handle • 2 incoloy heating elements (1 spare) 
84890	Full-time steam	110V/120V	Direct connection to a water supply line.	20-30 min	<ul style="list-style-type: none"> • Boiler thermostat reset switch • Heavy-duty adjustable feet • Uses regular tap water • Ranco pressure control • Automatic shut-off pump in event of water supply interruption. • 1 incoloy heating element • Blow down valve • 20-amp service supply required 

CNC SPINDLE MOUNTED CLEANING TOOL

Loads into CNC machine to quickly remove cured adhesive from grippers

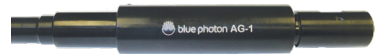
Part Number	Style	Description
82400	Gripper Cleaning Tool Assembly	<ul style="list-style-type: none"> • Mounts to any 3/4" Ø collet or end mill holder • Cleans an estimated 1,000 grippers • Not for use with corrosion resistant grippers 
82500	Replacement Head	Replacement head provides approximately 1,000 gripper cleanings

Contact us today to get started - 855-777-2040 • www.BluePhotonGrip.com • Sales@BluePhotonGrip.com

PRESSURIZED NEAT™ STEAM CLEANER

The space saving steamer provides pressurized steam for easy removal of residual cured adhesive from grippers and workpieces. Economical solution for prototypes or low-volume usage.

Part # 84750

- 10.5" x 10.5" x 9.5"
- 9 lbs
- 54 oz water capacity
- 120V
- Up to 275°F/135°C steam temperature
- Designed to prevent overfilling



HEATED SOAK TANK

The insulated, heated soak tank allows for debonding of the part from grippers without twisting. This method is preferred in applications where twist debonding could cause delamination or other damage to the workpiece.

Part #: 81312

- Stainless steel construction
- 5" interactive full-color touchscreen
- Immersion platform size: 23 x 20" (584 x 508 mm)
- Temperature range: 41°F - 203°F
- 14 gal. (56 L) water capacity
- 120V / 50-60 Hz / 1 – (12 A)
- External dimensions: 26 W x 23.6 D x 20.65 H inches
- 43 lbs



OPTIONAL SOAK TANK ACCESSORIES

INSULATED TANK LID

Stainless steel lid with handle for preventing water evaporation during heating process.

Part #: 81309



FLOATING BALLS

The floating balls are ideal for avoiding evaporation during the heating process.

Part #: 81310



SCRAPERS

Removes cured adhesive from parts and grippers.

Part Number	Material	Description
80030	Aluminum	Heavyweight adhesive removal blade
86005	Plastic	Flat edge, non marring



Base Workholding Components

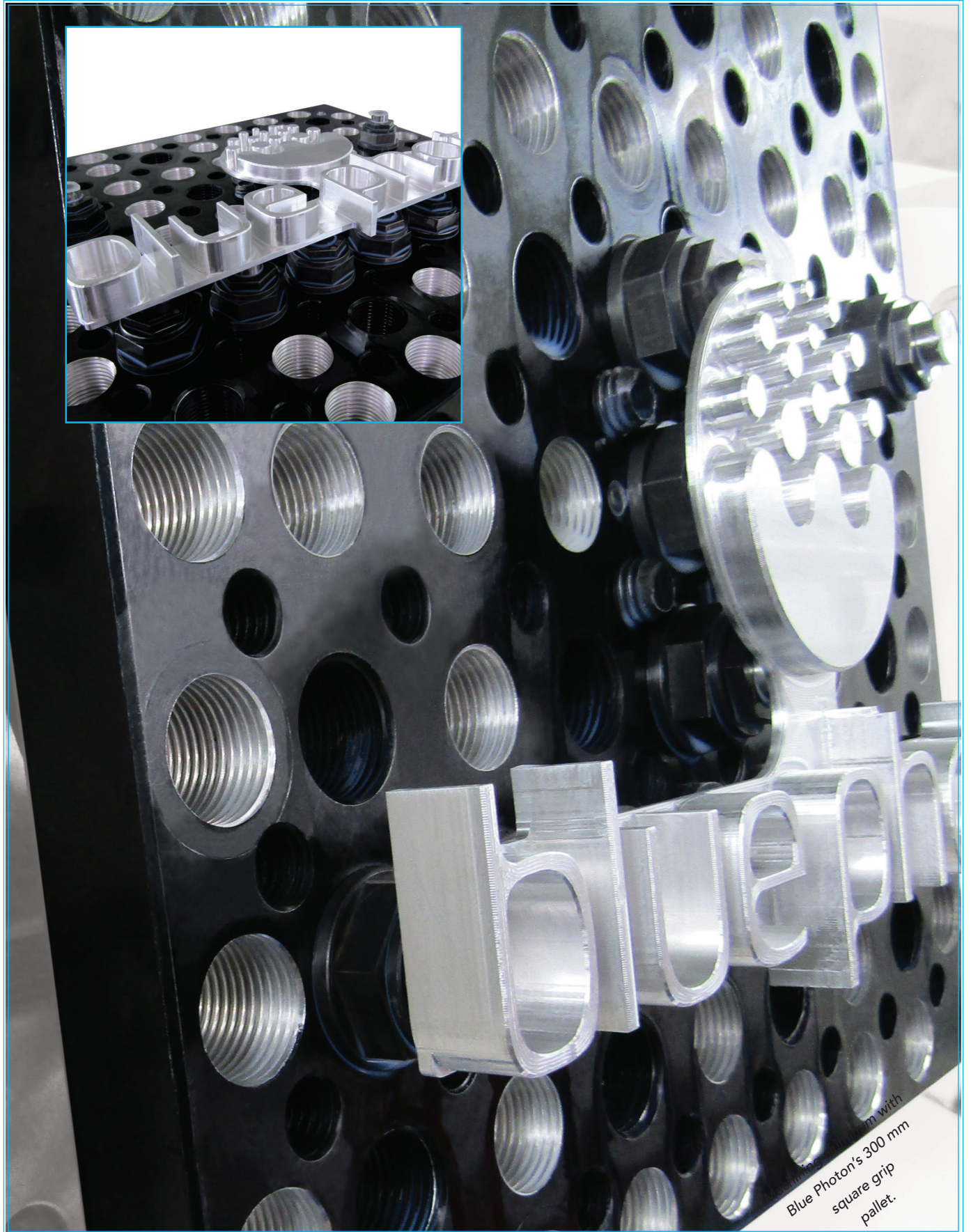

Blue Photon's 300 mm square grip pallet.

WORKHOLDING KITS

Blue Photon Workholding Kits

Workholding kits include all of the tools that you need to quickly start enjoying the benefits of Blue Photon's workholding technology.

Workholding kits include grippers in the optimal size for your applications bundled with a UV LED controller, light heads, adhesive, a manual adhesive plunger, and more!

Configure your custom kit to generate part number:

KIT	GRIPPER*	CONTROLLER	UV LED HEAD ASSEMBLY	UV LED HEAD QTY.	INSERT**
3	<input type="checkbox"/>	<input type="checkbox"/>	<input type="checkbox"/>	<input type="checkbox"/>	<input type="checkbox"/>
	1 - Small Head-In Gripper	1 - 4 Channel	1 - Small Adapter and 56 mm Head Length	1	1 - Small Gripper Internal Insert
	2 - Small Head-Out Gripper	2 - 8 Channel	2 - Small Adapter and 85 mm Head Length	2	2 - Small Gripper External Insert
				3	3 - Small Gripper External Fixed Insert
	3 - Medium Head-In Gripper		3 - Medium Adapter and 56 mm Head Length	4	4 - Medium Gripper Internal Insert
	4 - Medium Head-Out Gripper		4 - Medium Adapter and 85 mm Head Length	5	5 - Medium Gripper External Insert
				6	6 - Medium Gripper External Fixed Insert
	5 - Large Head-In Gripper		5 - Large Adapter and 56 mm Head Length	7	7 - Large Gripper Internal Insert
	6 - Large Head-Out Gripper		6 - Large Adapter and 85 mm Head Length	8	8 - Large Gripper External Insert
					9 - Large Gripper External Fixed Insert

*6 grippers included within each kit.

**Inserts optional with kit order.

In addition to the above items, each workholding kit contains:

- BlueGrip S2™ Workholding Adhesive®
- Manual Plunger
- Scraper
- Ratchet and Socket
- UV Safety Glasses
- Adhesive cleaning steamer

Actual unit may vary from one shown.



Store and protect your workholding kit with available hard case. See page 24 for details.

Blue Photon Workholding System Accessories

From ratchets for gripper removal to adhesive dispensing equipment, Blue Photon offers a full range of accessories designed to complement our base system.



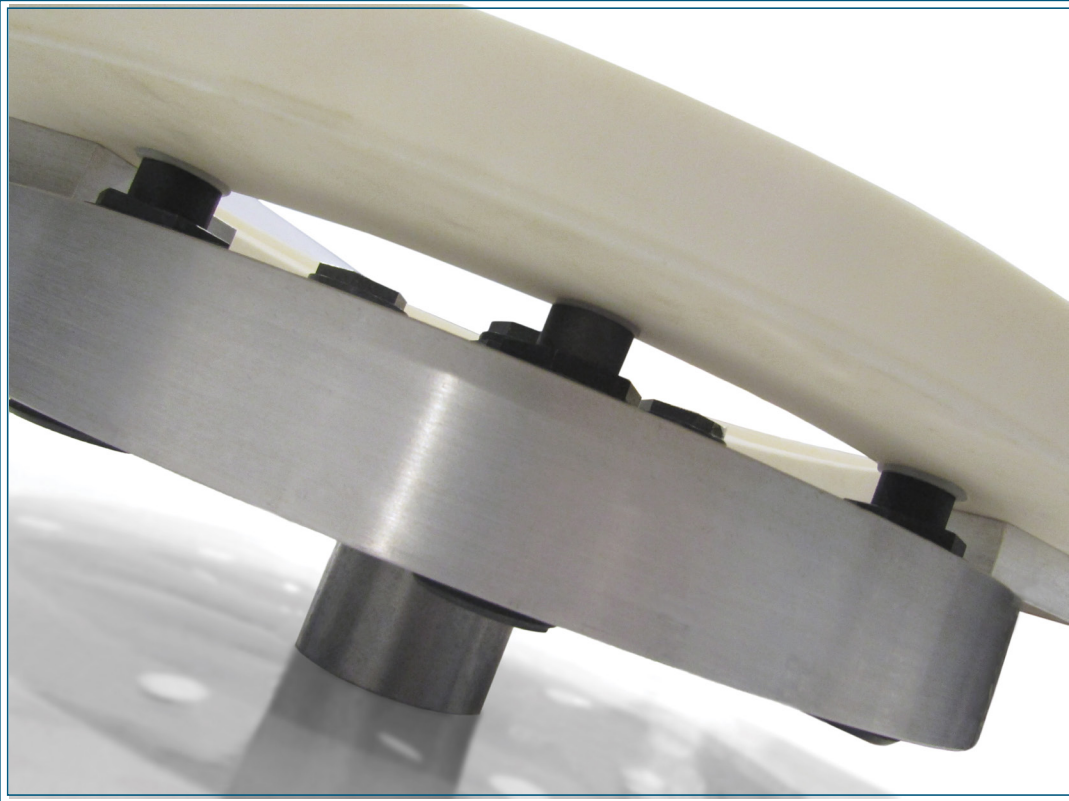

Project Spotlight - Ceramic Part

Challenge: Traditional workholding methods caused part damage due to the brittle nature of the ceramic material.

The Blue Photon workholding system allowed this customer to eliminate clamping which reduced scrap and part movement during machining while increasing output feed rates.

They were able to machine their brittle ceramic parts without damage, therefore improving quality.

The adhesive based workholding system allowed for easy automation of the customer's high value parts.



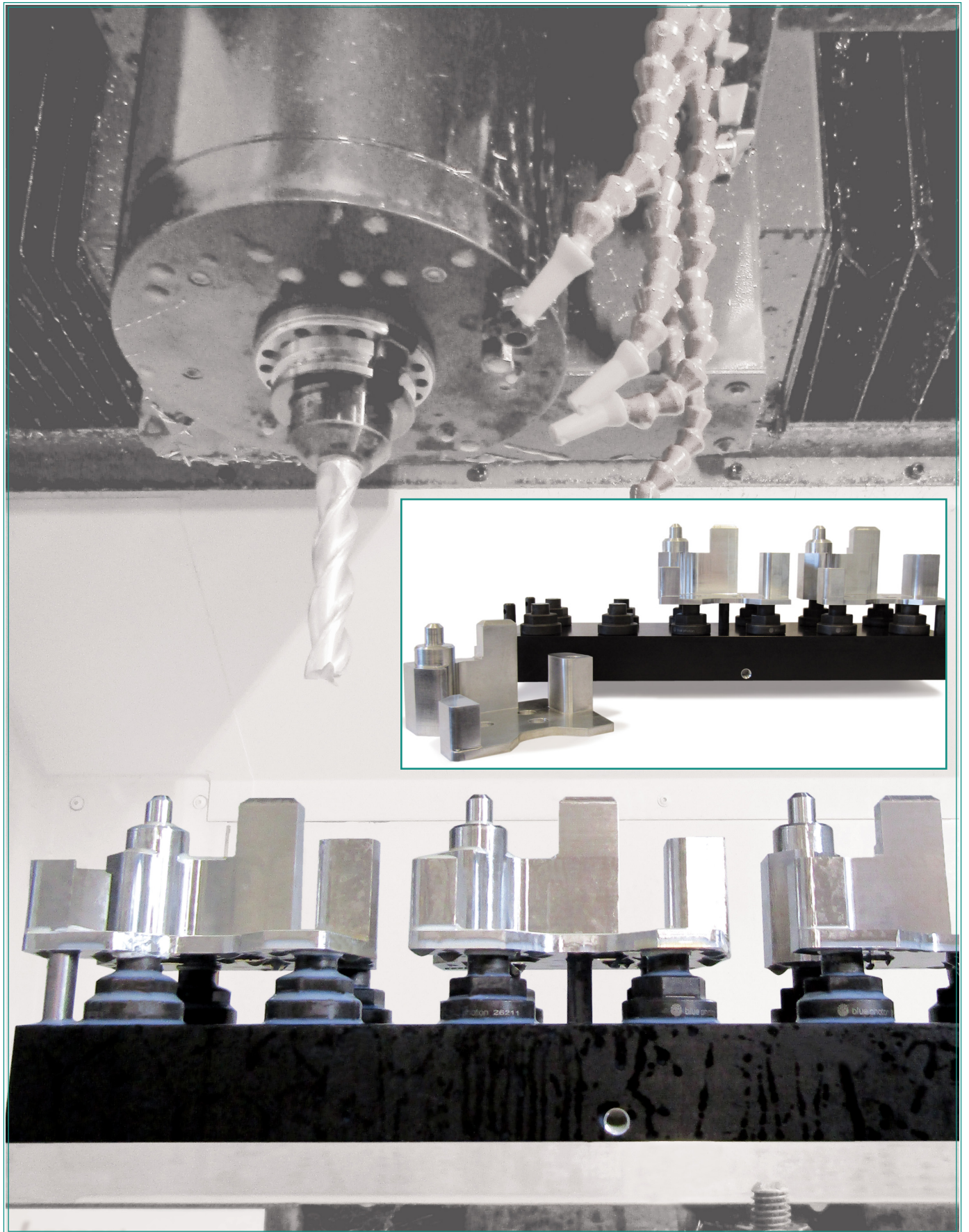

Contact us today to get started - 855-777-2040 • www.BluePhotonGrip.com • Sales@BluePhotonGrip.com

Tools for Gripper Handling.

RATCHETS

Use for the removal of Head-In Grippers.

Part Number	Supported Sockets	Description
50200	PN 54595 PN 58595	3/8" drive ratchet
52200	PN 51525	1/4" drive ratchet



THIN WALL DEEP WELL SOCKETS

Use to install or remove grippers within a fixturing system.

Part Number	Size	Compatible Gripper Size	Compatible Gripper Style
51525	1/4 drive, 8mm	Small	Head-In
54595	3/8 drive, 12mm	Medium	Head-In
58595	3/8 drive, 14 mm	Large	Head-In
52525	1/4 drive, 10mm	Small	Head-Out
55595	3/8 drive, 13mm	Medium	Head-Out
56595	3/8 drive, 16mm	Large	Head-Out



SHIMS

Stainless steel shims for gripper height adjustment.



Part Number	Size	Thickness	Outside Diameter	Inside Diameter	Compatible Gripper Style
51330	Small	.005"	.375"	.302"	Head-In
51430	Small	.010"	.375"	.302"	Head-In
55330	Medium	.005"	.574"	.465"	Head-In
55430	Medium	.010"	.574"	.465"	Head-In
58330	Large	.005"	.686"	.583"	Head-In
58430	Large	.010"	.686"	.583"	Head-In



Everything You Need For Adhesive Application

From simple, manual plungers to sophisticated, precise dispensing equipment, Blue Photon offers a range of adhesive dispensers compatible with BlueGrip™ workholding adhesives®.

ADHESIVE DISPENSERS

Part Number	Style	Description
71906	Pneumatic Dispenser	<ul style="list-style-type: none"> Digital time/pressure display. Foot-operated adhesive dispenser. Timed or steady modes of operation. Vacuum control keeps thin fluids from dripping between cycles. Optional electric finger switch (P/N 75490) available. 
73006	High Precision Dispenser with Optimeter	<ul style="list-style-type: none"> Electronically change/adjust dispensing time, pressure & vacuum. Auto-increment feature to adjust dispensing parameters after specified number of shots or lapsed time. Auto sequence mode for automatic repeat of deposit patterns 400 individual memory storage cells. Scroll or select cells via front panel keypad or external PC/PLC control. Switch between steady, timed and teach modes. Front panel manual cycle key. Teach function. Multi-level operator lockout. Alarm indicators. End of cycle feedback loop. Soft button data input 0-9 keypad. Operator control of LCD display brightness. Easy up/down arrow key navigation. External PC interface for data input. Display cycle counter. RS-232 communication capability. ESD safe via connection with external ESD. 0-100 psi (0-6.9) bar air regulation range. D-sub I/O (15-pin) and communication (9-pin) connections. Alarm I/O signals. 
77707	5 Gallon Pail Dispenser	<p><i>Use to efficiently fill smaller one liter cartridges with BlueGrip™ workholding adhesive®.</i></p> <ul style="list-style-type: none"> Single-post unloader. Manual bulk filling station. Fast air motor changeover with rapid-cycling, dual air-piloted cylinder providing uniform material output and consistent material pressure. Easy to operate front facing pneumatic controls featuring auto shutdown to prevent unit damage when the container bottom is reached. Removable packing gland allows for fast repair without removal of the pump from the line. Interchangeable follower plate and seal design reduce material waste and lengthy changeover procedures. Tapered solvent cup and finger safe design for CE compliance. Pail hold down feature prevents movement when the follower is withdrawn facilitating easy container changeover. 

Contact us for assistance in determining the best adhesive dispensing equipment for your applications.

Contact us today to get started - 855-777-2040 • www.BluePhotonGrip.com • Sales@BluePhotonGrip.com

ADHESIVE DISPENSING & SAFETY

BARREL LOADER

Barrel-filling system for BlueGrip™ workholding adhesive®.

Part # 46600

- Includes stand with retainer block.
- Use to fill 30 cc syringes from a 1 liter cartridge.





90° FITTING FOR BARREL LOADER

Adapter fits into the 1 liter cartridge to allow attachment of 30cc syringe.

Part # 75849

SAFETY AND MORE!

Part Number	Item	Description	
50010	UV Safety Glasses	99% protection against harmful UV rays. Meets ANSI Z87.1. Style may vary from the one shown.	
62020	Hand Held Radiometer	<ul style="list-style-type: none"> • Measures stray UV light output in the range of 280 to 400 nM. • Measuring range - 1 to 1999 uW/cm2, 0.01 to 40 mW/cm2 • Accuracy +/-4% +/- 1 digit • Backlit 4 digit LCD display • Data hold • Min/max memory • Memory - 20 point • Battery type - 9V • Cord length - 46" • Calibration Certificate - NIST 	
35000	Hard Case	Hard case with foam insert and custom made slots to hold workholding kit components.	

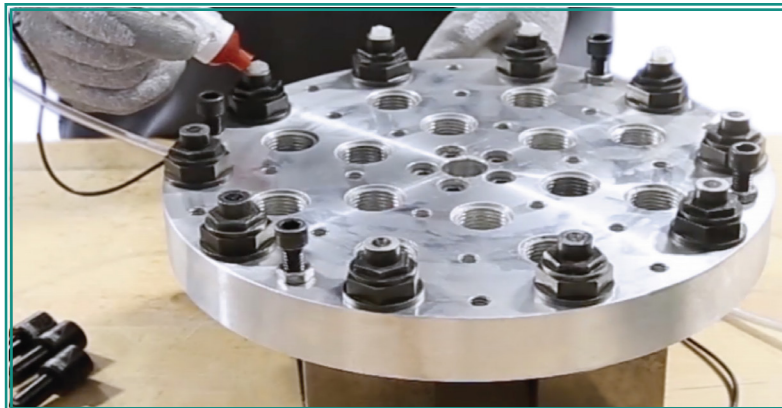

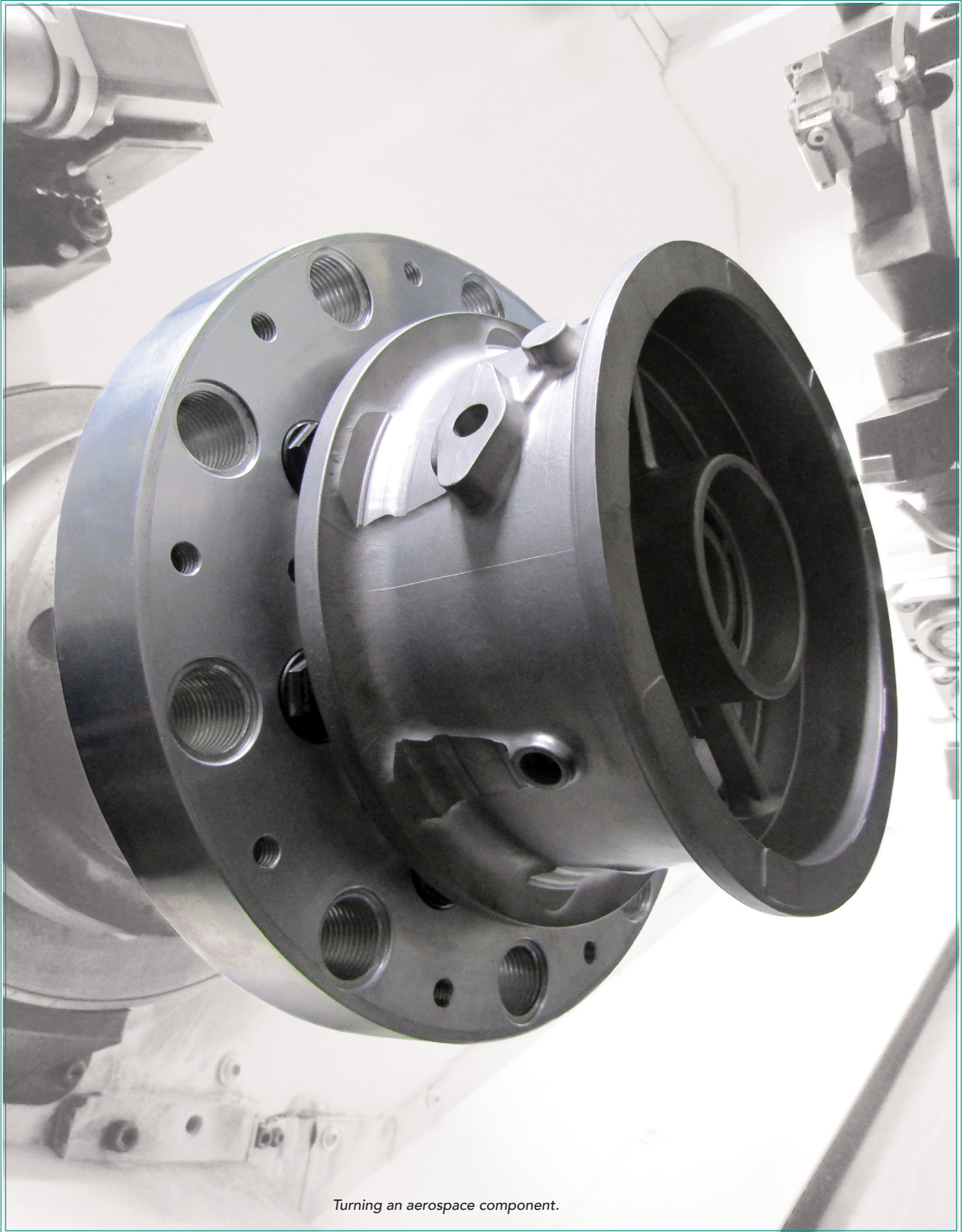

Turning an aerospace component.

Contact us today to get started - 855-777-2040 • www.BluePhotonGrip.com • Sales@BluePhotonGrip.com

ADHESIVE DISPENSING ACCESSORIES

SYRINGE AND CARTRIDGE BARRELS

Barrels block UV light while allowing monitoring of fluid levels.

Part Number	Size	Description	Qty
43402	30cc	Amber syringe barrel with piston and label	20/box
46402	1 liter	Amber cartridge barrel with piston and label	10/box

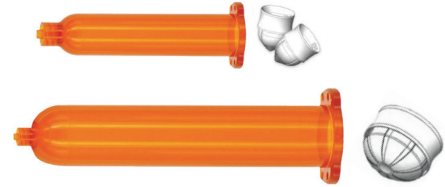

TIP CAPS

Tip caps protect BlueGrip™ workholding adhesive® from light exposure.

Part Number	Barrel Size	Description	Qty
43700	30cc	Amber syringe barrel tip cap	20/box
46700	1 liter	Amber cartridge barrel tip cap	10/box





END CAPS

End caps fit securely over syringe and cartridge tabs. A center push button easily ensures a snug, airtight seal.

Part Number	Barrel Size	Description	Qty
43800	30cc	Amber syringe barrel end cap	20/box
46802	1 liter	Amber cartridge barrel end cap	10/box



ADHESIVE DISPENSER ACCESSORIES

Part Number	Style	Description
74000	Manual Plunger	Fits into 30cc adhesive tubes for dispensing adhesive by hand. 
75880	Dispenser Adapter Assembly	Fits onto 30cc adhesive tubes for dispensing with pneumatic dispensers. <ul style="list-style-type: none"> • 6' (1.8 m) hose. • Required for operation of all automated dispensers using 30cc adhesive tubes. • Designed with a positive safety locking action to prevent accidental disengagement. • Easy to install and remove. • Precision molded to ensure secure attachment to the adhesive tube with minimal effort. 
48006	5 Gallon Pail Protector (10/box)	Extend seal life and reduce BlueGrip™ workholding adhesive® clean-up. Insert between the dispenser follower plate and the adhesive in the pail.
75112	Fine Point Applicator	18 Gauge dark green fine point applicator for 30cc amber syringe barrel. Qty: 50/box. 

Fixture Systems

The unique nature of the Blue Photon system and the parts that it holds can require special fixturing for maximum efficiency. Standard and custom items are compatible with existing quick change systems for the ideal combination of superior holding and time savings.

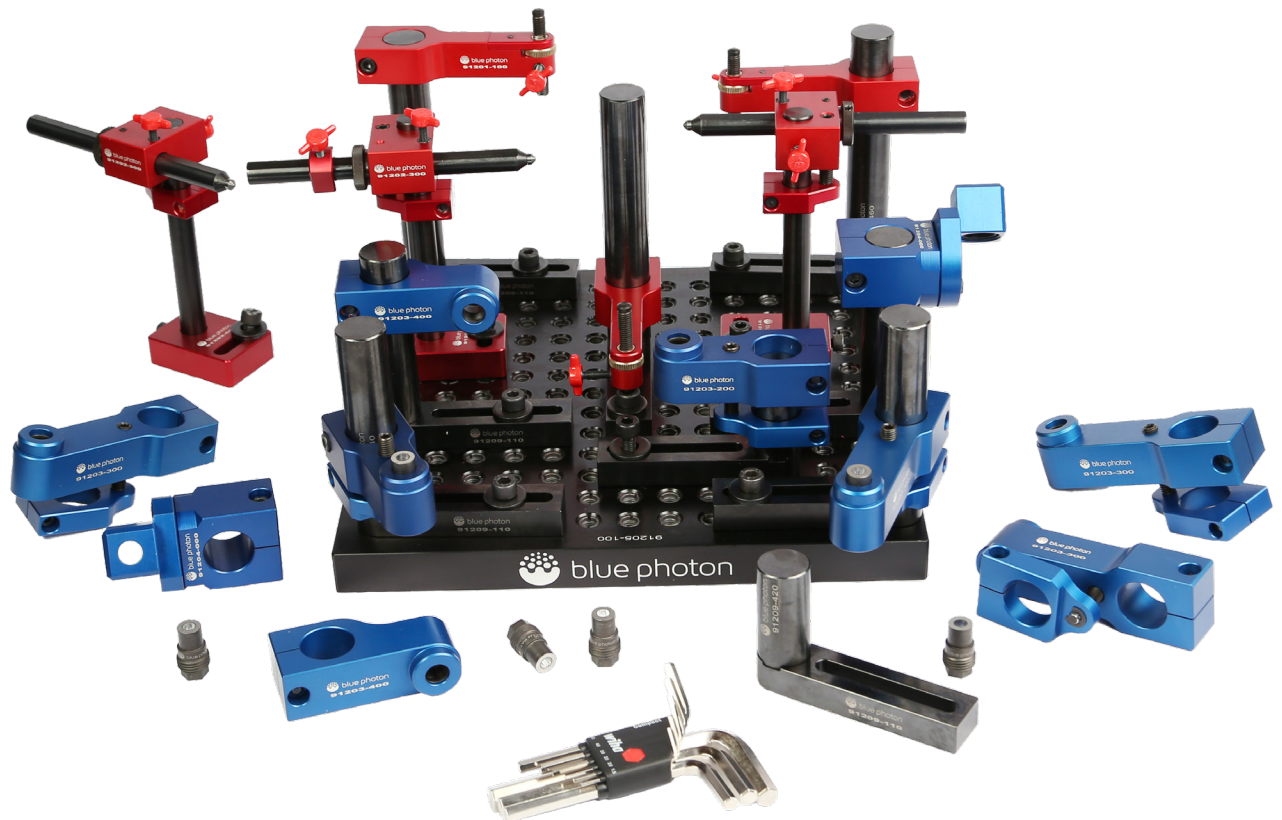

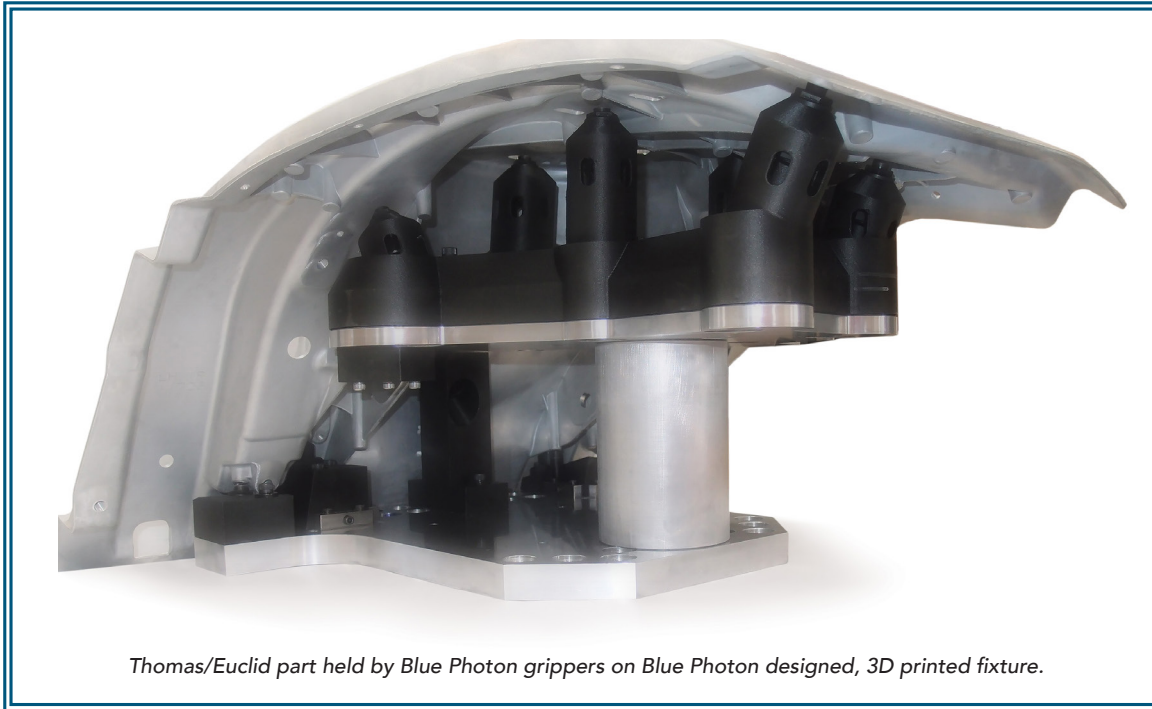

Thomas/Euclid part held by Blue Photon grippers on Blue Photon designed, 3D printed fixture.

Project Spotlight - Custom Fixtures

Challenge: Machining holes in an aluminum, odd shaped, 20-inch long, near-net aluminum casting with challenging tolerances.

This part had already been turned down by multiple shops due to its very challenging nature. Our customer was not a Blue Photon user, but found that adhesive workholding® was going to be the most viable option for holding this unique part.

Blue Photon application engineers successfully designed special fixtures using a combination of additively printed fixture components and Blue Photon grippers which then bolted into a quick change base.

By combining the Blue Photon gripper and adhesive workholding technology with custom fixtures and a quick-change base, our customer was able to successfully machine the part quickly and with a repeatability that other workholding systems could not come close to matching.



Grip Pallets

Blue Photon Grip Pallets for 52mm and 96mm quick change receivers allow for the use of existing fixturing systems in machine centers. These pallets are designed to simplify part loading, resulting in reduced scrap and increased spindle up time.

Clamp studs provide support for a wide range of workholding systems including 5th Axis, Erowa, Jergens, Lang, Mate, Schunk and others.

4 part spacers and 2 grip handles** are included with each grip pallet.

Please specify desired spacer part number when ordering pallets.

Part Number	Size	Receiver Size	Material	Gripper Insert Capacity*
96760	150mm	52mm	Steel	9
96770	150mm	52mm	Aluminum	9
96860	225mm	96mm	Steel	21
96870	225mm	96mm	Aluminum	21
96970	300mm	96mm	Aluminum	33

* Gripper and external inserts are sold separately.

** Grip handles are available in yellow, red, orange, black, gray or white.
Please specify color choice on purchase order.



Part Spacers

Part spacers ensure the required gap between the workpiece and gripper.

Standoff: 25.4mm

Height tolerance: +/- .025mm.

Part Number	Size (Ø)	Material
90400-3	15.9mm	Black oxide finish
90400-5	9.5mm	Black oxide finish
90470-5	9.5mm	Machinable aluminum



Clamp Studs

Clamp studs are available in 52mm and 96mm patterns to provide support for multiple workholding systems including 5th Axis, Erowa, Jergens, Lang, Mate, Schunk and other.

Part Number	Pattern	Pallet Size	Manufacturer
96500-61	52mm	150mm	5th Axis
96500-71	52mm	150mm	Jergens
96500-81	52mm	150mm	Lang
96500-91	52mm	150mm	Mate
96500-62	96mm	225mm & 300mm	5th Axis
96500-72	96mm	225mm & 300mm	Jergens
96500-82	96mm	225mm & 300mm	Lang
96500-92	96mm	225mm & 300mm	Mate



Universal Fixture

Blue Photon's **Universal Fixture** revolutionizes workholding for rapid prototyping and MORE!

Our Universal Fixture saves time and money when manufacturing one-offs and low volume parts or prototyping due to its capability to easily hold near-net shaped parts; including parts generated through additive manufacturing. This results in lower fixture costs and quick turn around times.

In short... time AND money saved!

Part # 91200

Each Universal Fixture arrives complete with the following pieces:

Part Number	Qty	Description	
91201-100	3	Z Locator Assembly	
91202-000	3	XY Locator Assembly	
91203-200	2	50mm Vertical Gripper Arm Assembly	
91203-300	4	75 mm Vertical Gripper Arm Assembly	
91203-400	2	Horizontal Gripper Arm Assembly	
91204-000	2	Pivoting Gripper Assembly	
91205-100	1	300mm Square Base Plate*	
91209-110	9	Shaft Foot	
91209-420	2	Shaft Support, 50mm Length	
91209-440	4	Shaft Support, 100mm Length	
91209-460	3	Shaft Support, 150mm Length	
15130	6	Medium Head-In Gripper	
64860	1	Right Angle Adapter, Extended Medium	

* Custom sizes available upon request.

Blue Photon offers custom fixture solutions!
Contact our engineers for assistance in designing application solutions.

Contact us today to get started - 855-777-2040 • www.BluePhotonGrip.com • Sales@BluePhotonGrip.com

UNIVERSAL FIXTURE

Workholding Fixture Systems



PART STABILIZATION



Stabilizer System

Our Stabilizer System combines Blue Photon grippers and inserts with components designed to stabilize your workpiece without drilling/tapping into your part.

Puck Bases

Each puck base holds three grippers and three external fixed inserts and can be adjusted and placed as necessary to stabilize your workpiece. They can be ordered with or without grippers and inserts.

Part Number	Included Gripper/Insert Qty	Gripper/Insert Size
98070	0	Not Included
98077	3	Small
98078	3	Medium
98079	3	Large



5-Axis Adjustable Stabilizer Bases

2 stabilizer balls are included with each stabilizer base. Clamps can be ordered separately.

Part Number	Length (L1)	Length (L2*)	Clamping Ball Size	Weight
98140	255-305 mm	187 mm	Ø25.4 mm	4.3 lbs
98150	400-550 mm	287 mm	Ø25.4 mm	5.3 lbs



* L2 at minimum position

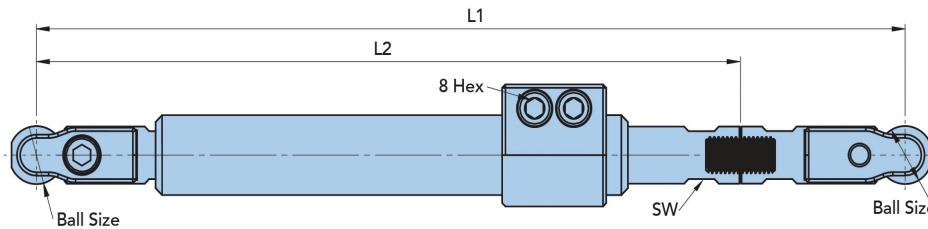

5-Axis Fine Adjustable Stabilizer Extension

Allows for adjustment of part position.

Part Number	Length	ØD1	Thread	Wrench	Weight
98200	120-160 mm	Ø25 mm	M16xP1.5	21 SW	2.6 lbs



Hex nut is included with extension.

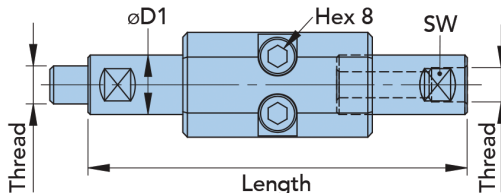

Contact us today to get started - 855-777-2040 • www.BluePhotonGrip.com • Sales@BluePhotonGrip.com

Stabilizer Mounting Screws

Part Number	Thread	Ball Size	Length	Weight
98330	M12xP1.75	Ø25.4 mm	40 mm	.4 lbs
98340	M14xP2	Ø25.4 mm	40 mm	.4 lbs
98350	M16xP2	Ø25.4 mm	40 mm	.4lbs
98360	M18xP2.5	Ø25.4 mm	40 mm	.4 lbs
98370	M20xP2.5	Ø25.4 mm	50 mm	.4 lbs
98380	M24xP3	Ø25.4 mm	50 mm	.9 lbs

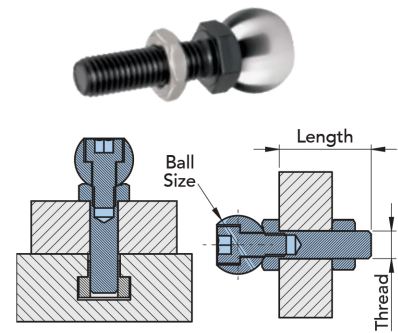

T-Nut is not included

5-Axis Stabilizer Ball and Collars

Allows for a variety of methods to attach and grab the workpiece(s).

Part Number	Description	Ball Size	Height	Weight
98418	Attachment ball with no location requirement (H=10).	Ø25 mm	25 mm	.2 lbs
98429	Ball and collar with location (H=25).	Ø25 mm	25 mm	.2 lbs

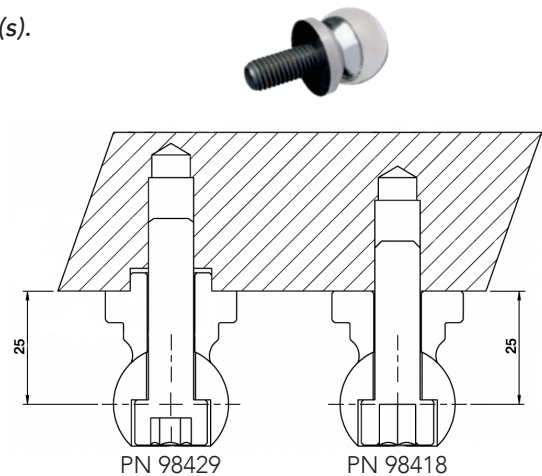

5-Axis Stabilizer Magnetic Bases

The base of the stabilizer system allowing it to be rigidly fixed in place.

Part Number	Fig.	Load Capacity	Ball Size	Ball Qty	Weight
98631	1	330 lbs/150 kg	Ø25.4 mm	1	7.5 lbs
98632	2	330 lbs/150 kg	Ø25.4 mm	2	7.5 lbs

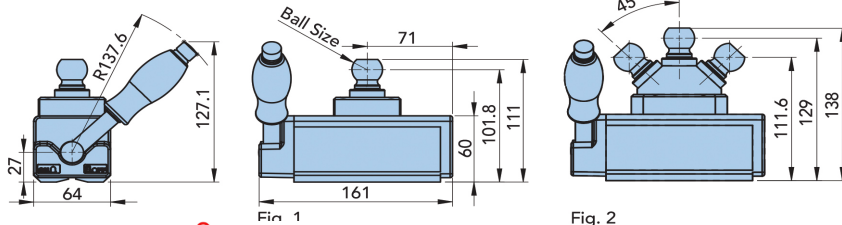
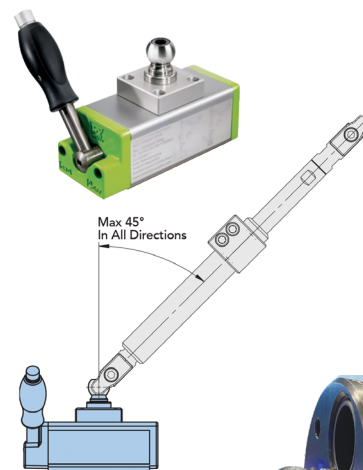

Not for lifting. Do not stand or lift loads overhead.



Contact us today to get started - 855-777-2040 • www.BluePhotonGrip.com • Sales@BluePhotonGrip.com

WARRANTY

Blue Photon is proud to offer a 3-year warranty on all Blue Photon grippers. Grippers are warranted against manufacturer's defects when used exclusively with BlueGrip workholding adhesives.

All other Blue Photon equipment is warranted for a period of one year from the date of delivery against manufacturing defects that affect the performance of the Blue Photon system. Equipment and supplies not manufactured by Blue Photon may have different manufacturer warranties.

Consult the information provided with the equipment or contact the Blue Photon sales team for additional information.

FAILURE TO USE BLUEGRIP WORKHOLDING ADHESIVES AND BLUE PHOTON APPROVED EQUIPMENT WILL VOID ALL WARRANTIES AND MAY SUBJECT THE USER TO UNSAFE CONDITIONS.



DESIGN CONSIDERATIONS

The user guide provides general operating procedures. Your specific application will have special considerations in setup, function and use. There are several design considerations that must be addressed before implementing Blue Photon workholding. Review these considerations with your design and engineering teams, including the number and position of grippers, adhesive joint temperature, adhesive cure time, amount of adhesive, setting the part on applied adhesive, and part and gripper cleaning.



CAUTION

The user guide as well as additional manuals provide a description of the function, application and safety considerations of the Blue Photon system. These manuals must be read and understood before any attempt is made to install or use this system. Improper use could result in damage to the product or unsafe conditions for the user. Follow these safeguards to prevent serious injury or property damage. Consult the factory on turning applications.



WARNING

Do not use the Blue Photon workholding system to hold overhead loads. The Blue Photon workholding system is not designed to support people. Never stand under a lifted fixture and/or part. If insufficient holding strength to resist cutting forces; or if improperly used, a workpiece may be ejected from the fixture at a high rate of speed. Always follow employer work instructions and Blue Photon user guide recommendations to minimize any risk. Always use proper guarding to protect people from injury due to a workpiece coming dislodged from the fixture.



PART NUMBER INDEX

P/N	Page	P/N	Page	P/N	Page	P/N	Page
14130.....	9	50200.....	22	58330.....	22	98079.....	33
14131.....	9	51330.....	22	58430.....	22	98140.....	33
14230.....	9	51430.....	22	58595.....	22	98150.....	33
14231.....	9	51525.....	22	62020.....	24	98200.....	33
15130.....	9	51705.....	13	64850.....	13	98330.....	34
15131.....	9	52200.....	22	64860.....	13	98340.....	34
15230.....	9	52525.....	22	64950.....	13	98350.....	34
15231.....	9	52705.....	13	64960.....	13	98360.....	34
16160.....	9	52802.....	14	65440.....	13	98370.....	34
16161.....	9	52803.....	14	65449.....	13	98380.....	34
16260.....	9	52804.....	14	71906.....	23	98418.....	34
16261.....	9	52810.....	14	73006.....	23	98419.....	34
24100.....	12	52812.....	14	74000.....	26	98429.....	34
24200.....	12	52815.....	14	75112.....	26	98500.....	34
24211.....	12	52850.....	14	75849.....	24	98631.....	34
24219.....	12	52855.....	14	75880.....	26	98632.....	34
25100.....	12	52860.....	14	77707.....	23	90400-3	30
25200.....	12	52865.....	14	80030.....	16	90400-5	30
25211.....	12	52870.....	14	81309.....	16	90470-5	30
25219.....	12	52875.....	14	81310.....	16	91201-100	31
26100.....	12	53802.....	14	81312.....	16	91202-000	31
26200.....	12	53803.....	14	82400.....	15	91203-200	31
26211.....	12	53804.....	14	82500.....	15	91203-300	31
26219.....	12	53810.....	14	84750.....	16	91203-400	31
35000.....	24	53812.....	14	84870.....	15	91204-000	31
43200.....	10	53815.....	14	84880.....	15	91205-100	31
43210.....	10	53850.....	14	84881.....	15	91209-110	31
43402.....	26	53855.....	14	84890.....	15	91209-420	31
43700.....	26	53860.....	14	86004.....	16	91209-440	31
43800.....	26	53865.....	14	86005.....	16	91209-460	31
46200.....	10	53870.....	14	96760.....	29	96500-61	30
46210.....	10	53875.....	14	96770.....	29	96500-62	30
46402.....	26	54595.....	22	96860.....	29	96500-71	30
46600.....	24	55330.....	22	96870.....	29	96500-72	30
46700.....	26	55430.....	22	96970.....	29	96500-81	30
46802.....	26	55595.....	22	98070.....	33	96500-82	30
48006.....	26	56595.....	22	98077.....	33	96500-91	30
48300.....	10	57705.....	13	98078.....	33	96500-92	30
50010.....	24						



Sales and Engineering Support
Blue Photon Technology & Workholding Systems LLC
1002 Industrial Park Dr., Shelby, MI 49455
sales@BluePhotonGrip.com

www.BluePhotonGrip.com • 855-777-2040

©2024 Blue Photon Technology & Workholding Systems LLC. All Rights Reserved. Blue Photon Technology & Workholding Systems LLC assumes no responsibility for any errors or omissions in this document. This document is for reference only and actual application will vary according to the application. Blue Photon has made every effort to ensure the accuracy of the product information in this document; however, we are not responsible for typographical discrepancies. Actual products may vary from those shown in photos. Refer to our website for current product and safety information. 2024-25 Product Catalog 10551 08.13.24 Revision 1